

**MABUCHI  
MOTOR**

# RS-555SH

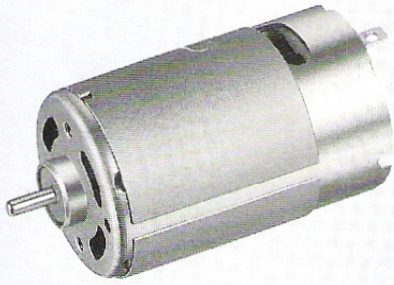

DIRECTION OF ROTATION

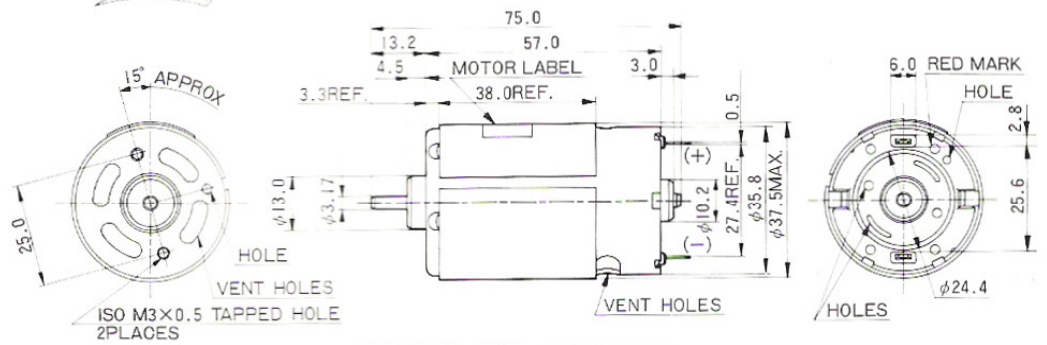

WEIGHT: 209g (APPROX.)

MODEL	VOLTAGE		NO LOAD		AT MAXIMUM EFFICIENCY						STALL TORQUE	
	OPERATING RANGE	NOMINAL	SPEED	CURRENT	SPEED	CURRENT	TORQUE		OUTPUT	EFF	STALL TORQUE	
			rpm	A	rpm	A	oz-in	g·cm	W	%	oz-in	g·cm
RS-555SH-18150	18.0~30.0	24.0V CONSTANT	4150	0.09	3430	0.43	2.64	190.2	6.70	64.8	15.3	1100
RS-555SH-2670	9.0~30.0	12.0V CONSTANT	4450	0.19	3680	0.91	2.65	191.0	7.22	65.8	15.4	1110
RS-555SH-2670	9.0~30.0	24.0V CONSTANT	9100	0.21	7810	1.27	3.94	283.5	22.7	74.4	27.8	2000
RS-555SH-3250	6.0~30.0	24.0V CONSTANT	12300	0.32	10710	2.15	4.85	349.2	38.4	74.2	37.5	2700
RS-555SH-4525	4.5~20.0	6.0V CONSTANT	6000	0.5	5100	2.83	3.01	217.8	11.4	67.1	20.14	1450
RS-555SH-4525	4.5~20.0	12.0V CONSTANT	12400	0.6	10790	4.03	4.59	330.8	36.6	75.8	35.4	2550

## RS-555SH-18150

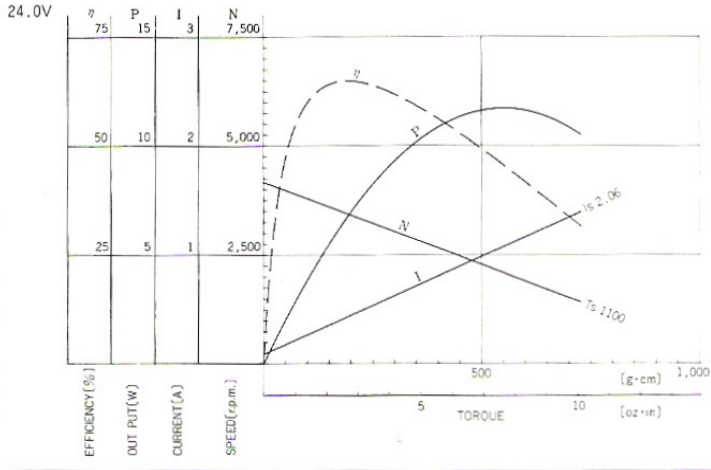

## RS-555SH-2670

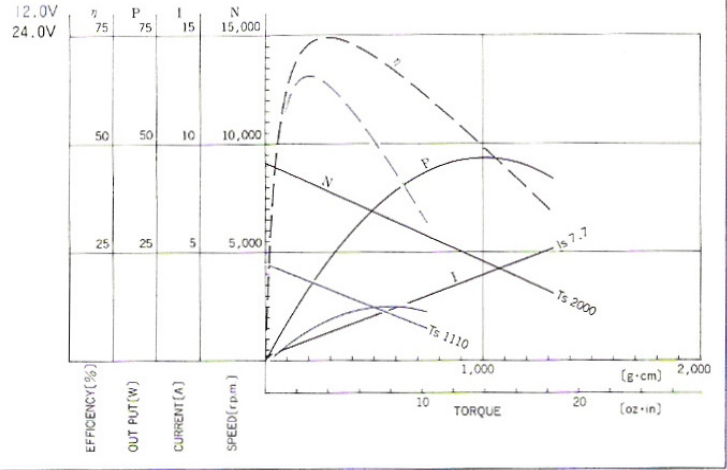

## RS-555SH-3250

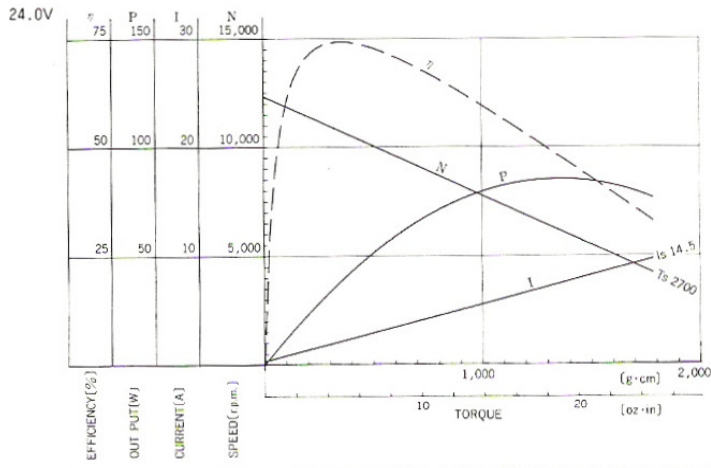

## RS-555SH-4525

