



# RF-500

**AP&S**  
MOTORREDUCTORES

Posibles aplicaciones:

Peso:



## Características

MODEL	VOLTAGE		NO LOAD		AT MAXIMUM EFFICIENCY				STALL			
	OPERATING RANGE	NOMINAL	SPEED r/min	CURRENT A	SPEED r/min	CURRENT A	TORQUE mN-m	TORQUE g-cm	OUTPUT W	TORQUE mN-m	TORQUE g-cm	CURRENT A
RF-500TB-14415	1.5~9.0	5V CONSTANT	3100	0.026	2540	0.12	1.23	12.6	0.33	6.86	70	0.54
RF-500TB-12560	1.5~12.0	6V CONSTANT	2700	0.020	2180	0.084	1.13	11.6	0.26	5.88	60	0.35

## Dimensiones

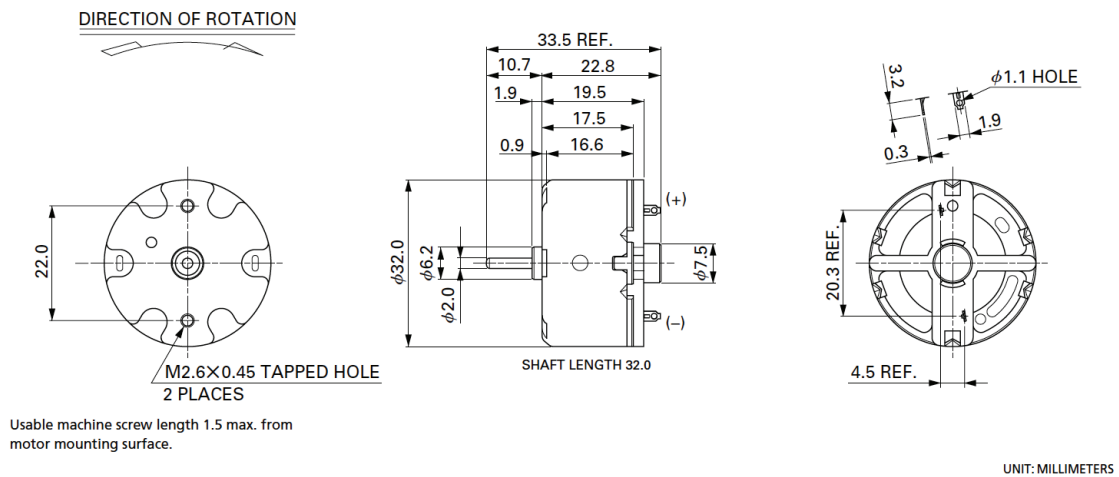

## Curva de funcionamiento

